

# N-COM

On-front dimming

External dimming

Central dimming

Multi dimming

Single knob full OSD control

## Contents

1	Introduction .....	3
2	System overview .....	5
3	Hardware and pinning.....	6
4	Addressing for dimming and commands .....	8
4.1	NET ID and Unit numbers (ID) .....	8
4.2	Multi Dimming control setup .....	9
5	Protocol.....	10
5.1	N-COM.....	10
5.1.1	Dimming format.....	10
5.1.2	Function and OSD control format .....	11
5.1.3	DataKeys, miscellaneous functions:.....	17
5.2	S-Com (alternative RS-485) option .....	20
5.2.1	Switch from N-COM to S-COM.....	21
5.2.2	Switch from S-COM to N-COM.....	21
6	N-COM Application .....	22
6.1	System network.....	23
6.2	ID-list .....	23
6.3	Read, write and store .....	24
6.4	Configuration-tab .....	24
6.5	Unit ID and state.....	24
6.6	LIN-Bus module .....	24
6.7	Control Backlit settings.....	24
6.8	Configuration of dimming sources .....	24
6.9	Setting the dimming curve. ....	25
6.10	Backlight settings.....	25
6.11	Miscellaneous functions .....	25
7	Installation and parameter settings .....	26
7.1	Configuration plan .....	26
8	Example configuration central dimming .....	27
8.1.1	Factory default and 0-configuration .....	33
9	Firmware update.....	34
10	Trouble shooting .....	35

## Revision history

Before installation or using the monitor make sure you have the latest version of this owner's manual.

Version	Remark
N-COM_Setup_V1.0	Initial manual
N-COM_Setup_V1.01	Minor corrections
N-COM_Setup_V1.02	OSD > Push&hold functions added
N-COM_Setup_V1.03	Protocol description
N-COM_Setup_V1.04	ACK command correction 99 > 06 Master text removed (par 4.1) S-COM protocol settings updated
N-COM_Setup_V1.05	Paragraph 5.1.3 DataKeys, miscellaneous functions added Paragraph 5.3 Text
N-COM_Setup_V1.06	SDI input added

## About this manual

The N-COM is a dimming control system designed for Nottrot N-Line models. Since all models are built using the same concept (similar components), all data has been collected to create one manual that describes the entire series.

This document contains technical and user information about the dimming system and must be used with the manual of your type of monitor, like N-Line. Please make sure you are using the latest version of this manual when installing the product. Although we strive to be as complete as possible, there will always be additions made. All updates of this document are subject to change without notice. The revision history is shown in chapter 1.

## Disclaimer

Nottrot BV makes no representations or warranties, either expressed or implied, with respect to the contents hereof and specifically disclaims any warranties, merchantability or fitness for any particular purpose. Further, Nottrot BV reserves the right to revise this publication and to make changes from time to time in the contents hereof without obligation of Nottrot BV to notify any person of such revisions or changes. Please follow these safety instructions for the best performance and longevity of the monitor.

Copyright © 2023 by Nottrot BV. All rights reserved. No part of this publication may be reproduced, transmitted, transcribed, stored in a retrieval system or translated into any language or computer language, in any form or by any means, electronic, mechanical, magnetic, optical, chemical, manual or otherwise, without the prior written permission of Nottrot BV.

# 1 Introduction

N-COM is an advanced dimming system for N-Line monitors. This digital system can be used for controlling various functions like OSD-control and dimming of your LCD monitor. N-COM also makes it possible to interconnect up to 18 monitors for central dimming and (basic) control. The units will be addressed automatically.

➔ With the N-COM application software you are able to set all kinds of parameters described in this manual.

The advantage of the N-COM with LIN-Bus and RS-485 is the supported long cable length. It supports auto-addressing and patching of any dimming control-unit to any other monitor.

## Safety precautions

- Consider this document as an addendum on the N-Line monitor manual.
- Remove power before (dis)connecting any cables to the monitor.
- Connecting the RS-485 (LAN/CAT5) cable to a computer network may result in damage to the devices in the network and the monitor.
- The cover glass or touch sensor is made of regular (or hardened) glass. This can be scratched or even broken in pieces by hitting it.
- In case of trouble contact your supplier. Service should only be done by qualified personal.
- Never open the chassis. There are no user-serviceable parts inside.
- Never place any parts of the monitor system near warm objects like heaters or in direct sunlight.
- Keep all parts dry to avoid short circuit. Make sure no fluids can enter the units through any ventilation gaps.
- Wait for at least 6 seconds after switching power off before removing the cables.
- Make sure the temperatures do not exceed max values when storing or using the display.

- Never expose the unit to strong vibrations during transport and use.

## 2 System overview

Basically, N-COM is introduced for advanced dimming of N-Line monitors. With this system you are able to control OSD and dimming levels from the front of the monitor, but you can also control it remotely with a NControl, PLC or PC by means of RS-485 (using a USB adapter cable) or with a LIN-Bus dimming knob. LIN-Bus (Local Interconnect Network) is a serial network protocol used for communication between components (single wire/12VDC). In this chapter the hardware configurations will be described.

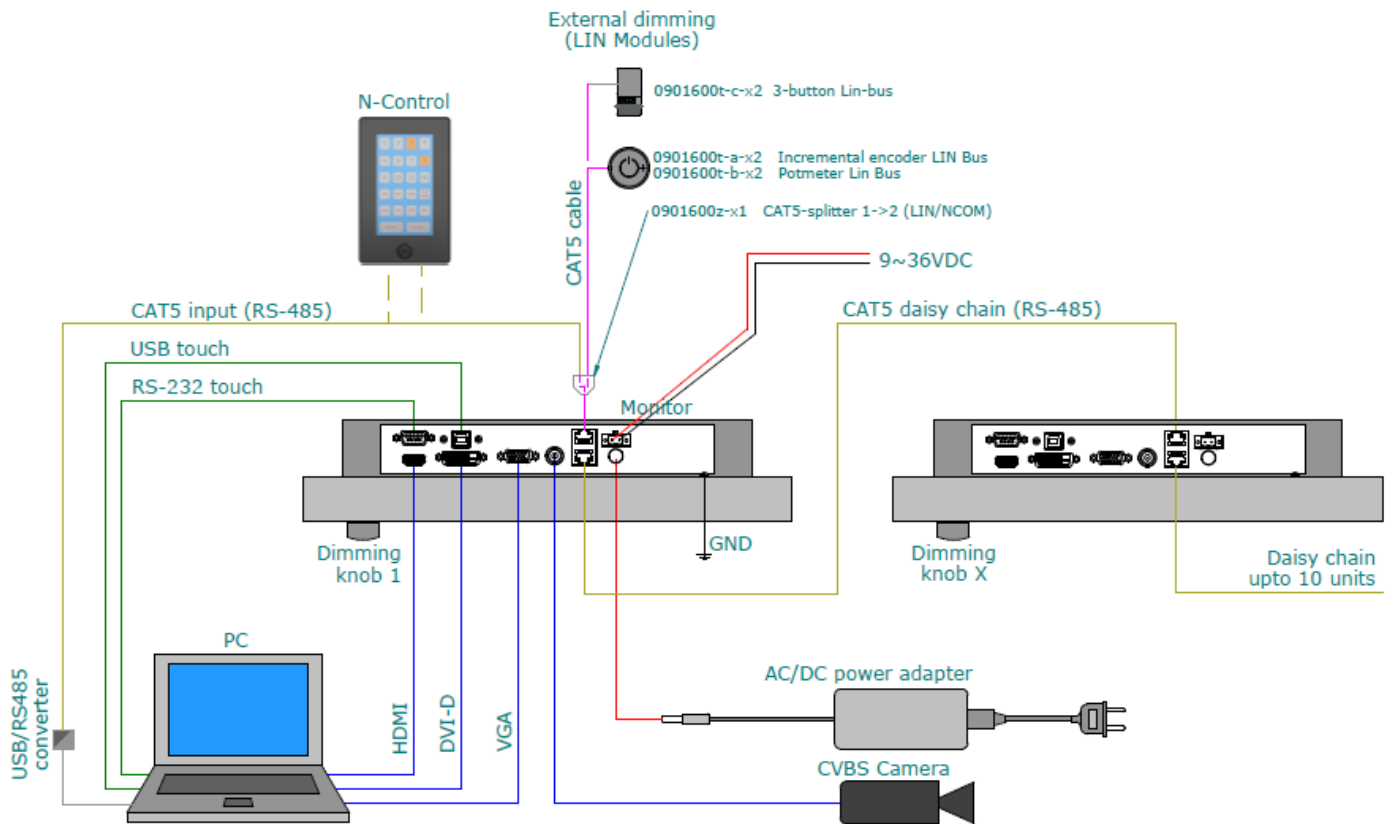
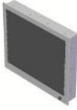

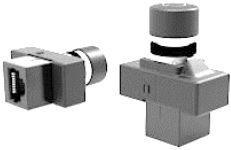
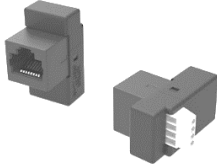





Figure 2-1 System overview

### 3 Hardware and pinning

#### Available hardware components

Image	Description	Remark
	Monitor with N-COM option	
	NControl	Remote dimming and preset selections
	External encoder or potentiometer with LIN-Bus and LED-backlight	Can be mounted on a 1mm or 4mm front plate.
	External converter LIN-Bus to 3-button dimming and OSD control	For momentary switches +, - and power
	RJ45 splitter	Connect RS-485 and dimming knob
	CAT5 cable	Used for inter-connection of monitors (RS-485 protocol)
	Converter cable USB to RS-485	For programming and communication with other computer equipment

## Connectors at I/O bracket

For connecting the units to a controller and daisy chain, there are 2 connectors located in the I/O bracket.

→ The RJ45 connectors are not compatible with LAN protocol. ←



Figure 3-1 I/O Bracket with RJ45 N-Com connectors

- 1- NCOM-IN: RS-485 input, dimming knob, daisy chain IN
- 2- NCOM-OUT: Daisy chain output to other/next monitor

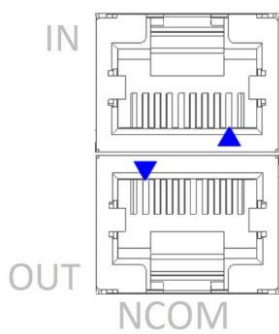

Pin	IN	OUT
1	12V (LIN power)	
2		
3	LIN-Bus	
4	RS-485 D+	RS-485 D+
5	RS-485 D-	RS-485 D-
6		
7		
8	GND	GND

## 4 Addressing for dimming and commands

### 4.1 NET ID and Unit numbers (ID)

N-COM uses auto addressing (NET-ID=logic address), which ensures that you always have access to the entire network. Even though there are duplicate unit numbers in use. The first unit (monitor or NControl\*) in the chain is assigned logic address 1 and acts as master for the chain.





It is also possible, without additional settings, to add peripheral equipment such as Ncontrol and VariCap. A user who does not use the advanced functions such as control with the PLC will not notice a NET-ID. The NET-ID is also used to exchange dimmer data in a fast way, so that you have a nice smooth dimming function, regardless of the number of sources.

A unit number can be set by the user in the N-COM app. All commands sent by an external controller (PLC, PC, etc.) will be distributed in the daisy chain by the master. A reply will always be given by the master, NET-ID1.

\*) NControl is a 4.3" touch screen device to control dimming and functions of the monitors in the chain.

→ Notations: ①=NET ID, ①=Unit Number, (1)=Source

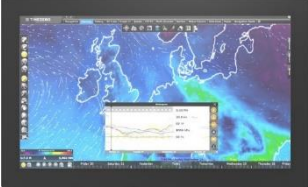
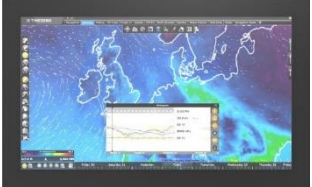
Example of a simple daisy chain with 3 monitors with and without a NControl:

Unit in the chain	NET ID (Logic address)	Unit number (Set by user)	Unit in the chain	NET ID (Logic address)	Unit number (Set by user)																																													
	①			①	①																																													
	②	①		②	②																																													
	③	②		③	③																																													
	④	③																																																
N-COM APP:	<b>System network</b> Network: On line Select com port: COM3 Open port Identify Lookup <table border="1"> <thead> <tr> <th>Net ID</th> <th>Unit</th> <th>Serial</th> <th>Identify</th> <th>State</th> </tr> </thead> <tbody> <tr> <td>1</td> <td>255</td> <td>3</td> <td>-</td> <td>App.</td> </tr> <tr> <td>2</td> <td>1</td> <td>2081</td> <td>-</td> <td>App.</td> </tr> <tr> <td>3</td> <td>2</td> <td>5076</td> <td>-</td> <td>App.</td> </tr> <tr> <td>4</td> <td>3</td> <td>5125</td> <td>-</td> <td>App.</td> </tr> </tbody> </table>		Net ID	Unit	Serial	Identify	State	1	255	3	-	App.	2	1	2081	-	App.	3	2	5076	-	App.	4	3	5125	-	App.	N-COM APP:	<b>System network</b> Network: On line Select com port: COM3 Open port Identify Lookup <table border="1"> <thead> <tr> <th>Net ID</th> <th>Unit</th> <th>Serial</th> <th>Identify</th> <th>State</th> </tr> </thead> <tbody> <tr> <td>1</td> <td>1</td> <td>2081</td> <td>-</td> <td>App.</td> </tr> <tr> <td>2</td> <td>2</td> <td>5076</td> <td>-</td> <td>App.</td> </tr> <tr> <td>3</td> <td>3</td> <td>5125</td> <td>-</td> <td>App.</td> </tr> </tbody> </table>		Net ID	Unit	Serial	Identify	State	1	1	2081	-	App.	2	2	5076	-	App.	3	3	5125	-	App.
Net ID	Unit	Serial	Identify	State																																														
1	255	3	-	App.																																														
2	1	2081	-	App.																																														
3	2	5076	-	App.																																														
4	3	5125	-	App.																																														
Net ID	Unit	Serial	Identify	State																																														
1	1	2081	-	App.																																														
2	2	5076	-	App.																																														
3	3	5125	-	App.																																														

Available unit numbers:

- ① Reserved for zero configuration
- ②-⑱ Available for user
- ⑳ Central dimming
- ㉑-㉓ Reserved for NControl
- ㉔ Reserved for VariCAP backlit Zones

Now that we know the structure of NET-ID's and Unit numbers we can look at the way dimming and function control uses these numbers.



→ Dimming is based on Unit-sources and commands are based on logic addresses.

4.2 Multi Dimming control setup

Multi Dimming is a term used for dimming monitors in many different ways using different dimming sources. Multi Dimming is a key-feature of the N-COM system and it ensures a very flexible way of dimming and function control. Dimming of a monitor can be controlled by its own dimming knob, a dimming knob from another monitor or RS-485 HEX-commands or a combination from these.

Basically a monitor will follow a dimming level of a Unit Numbers-Source, notation ①-(1). Per Unit Number up to 4 sources can be set for dimming level.

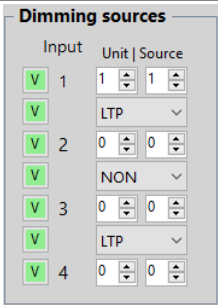
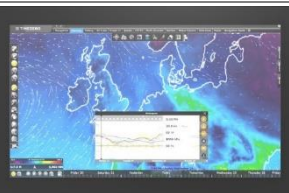
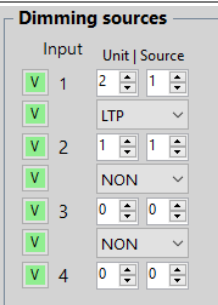
Example of dimming control in a daisy chain with 3 units:

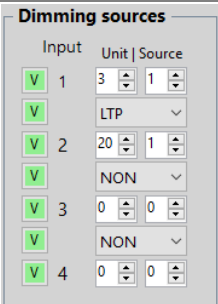
Unit in the chain	Unit number (Set by user)	Dimming control by	NCOM-settings
	①	①-(1) On-front encoder	
	②	②-(1) ①-(1) On-front encoder + Encoder of unit 1	
	③	③-(1) ⑳-(1) On-front encoder + external control	

## 5 Protocol

The monitors can be controlled by an external RS-485 command. The standard protocol is N-COM. As an option the monitor can be set to use the S-COM protocol.

→ The RS-485 commands are actively forwarded by each monitor, like a repeater. An un-powered monitor will break the chain.

→ The master (the first device in the chain) is the communication partner for the PC/PLC. A reply will always be addressed from the master.

### 5.1 N-COM

Communication settings:

- RS-485
- Half duplex
- Frame based
- Baud rate 115200 (→ Do not change the original RS-232 baud rate 38400 in the unit! ←)
- Data bits 8
- 1 stop bit
- no parity

A message always consist of a start (0x02) and stop (0x03) byte, address to send to, command, length of data bytes and checksum. The length of data can be 0 to 79. See complete description and example in the N-COM-protocol Excel sheet (available on request).

All commands and listed in: N-COM-protocol\_x.x.xlsx, where x.x is version. Please contact us to receive a copy.

Checksum: sum all data in hex: 02+01+99+05+14+00+10+80+FF and inverse the byte, take lsb.

#### 5.1.1 Dimming format

The data package for N-COM dimming has following format:

(fixed)

STX	Address Always 01 (master)	Command	Data length	Unit nr (DEC to HEX)	Level source 1	Level source 2	Level source 3	Level source 4	Checksum	ETX
0x02	0x01	0x99	0x05	0x14	0x00	0x10	0x80	0xFF	0xBB	0x03

0x02= 02 start code. Always 0x02

0x01 = 01 = master monitor. Always 0x01. The master processes all data from the PC or PLC and takes care the other units also get these data. A reply is always sent to the PC / PLC! Do not send a new message before the reply is received.

0x99 = command. Always 0x99 for external level

0x05 = amount of bytes

0x14 = unit number, in this case unit / monitor number 20 (HEX 14)

0x00 = level source 1, level to be processed by each unit which listen to unit 8 , source 1. Dimming level is 0

0x10 = level source 2, see source 1, but level 10(hex) 16(dec)

0x80 = level source 3, see source 1, but level is 0x80(hex) 128(dec)

0xFF = level source 4, see source 1, but level is 0xFF ( hex) 255 (dec) = maximum level

0xBB = checksum: sum all data (byte 0..8) in hex: 02+01+99+05+14+00+10+80+FF and inverse the byte, take lsb.

0x03 = end of frame, always 0x03. No part of checksum.

Reply, always the same:

STX	Address Always 01 (master)	Command	Data length	Checksum	ETX
0x02	0x01	0x9A	0x00	0x62	0x03

## 5.1.2 Function and OSD control format

Function control of monitors is based on logic addresses (NET ID). Function control is only available from the NControl and external RS-485 commands. The command is addressed to a NET ID in the chain. This command is distributed by NET ID 1 (master) to the slave units. The master will send a replay.

- Sending a command to any unit in the chain will always have a reply from the 1<sup>st</sup> unit, the master.  
When a NControl is used in the chain, this will be the master. The 1<sup>st</sup> monitor in the chain will have NET ID 2

The data package for N-COM function control format:

(fixed)

	STX	Address	Command	Data length	Data	Checksum	ETX
ACK	0x02	0x01	0x06	0x00	-	Y	0x03
NACK	0x02	0x01	0x15	0x00	-	Y	0x03
GetSoftwareVersion	0x02	0xnn	0x85	0x00	-	Y	0x03
ReplySoftwareVersion	0x02	0x01	0x86	0x02	Data[0], data[1]	Y	0x03
Identify	0x02	0xnn	0x89	0x01	Data[0]	Y	0x03
Setkey	0x02	0xnn	0x94	0x04	Data[0] to data[3]	Y	0x03
GetKey	0x02	0xnn	0x95	0x02	Data[0], data[1]	Y	0x03
GetKeyReply	0x02	0xnn	0x96	0x06	Data[0] to data[5]	Y	0x03
LookupRequest	0x02	0xnn	0xA0	0x00	-	Y	0x03
LookupReply	0x02	0xnn	0xA1	0x12	Data[0] to data[11]	Y	0x03
StoreData	0x02	0xnn	0xB0	0x00	-	Y	0x03

For detailed info, please refer to NCOM-protocol XLS

Notes:

- To store data from RAM to EEPROM use [StoreData 0xB0] command

### 5.1.2.1 OSD control

OSD function control have a longer response time than dimming.

The data package for OSD function control format:

(fixed)

	STX	Address	Command	Data length	Data (0) Command	Data (1) Data Type	Data (2) Data	Checksum	ETX
OSDGetSetKeys	0x02	0xnn	0xBA	0x03	0xXX	0xXX	0xXX	Y	0x03
OSDReturnKeys	0x02	0xnn	0xBB	0x03	0xXX	0xXX	0xXX	Y	0x03

Packet	Command	Data Type	Data				Command	Data Type	Data			
REMOCON	01	00	00	IRKEY_POWER	01	00	00	IRKEY_POWER				
			12	IRKEY_INPUT_SOURCE			12	IRKEY_INPUT_SOURCE				
			03	IRKEY_AUTO			03	IRKEY_AUTO				
			02	IRKEY_MENU			02	IRKEY_MENU				
			05	IRKEY_UP			05	IRKEY_UP				
			0D	IRKEY_DOWN			0D	IRKEY_DOWN				
			08	IRKEY_LEFT			08	IRKEY_LEFT				
			0A	IRKEY_RIGHT			0A	IRKEY_RIGHT				
			0C	IRKEY_AV			0C	IRKEY_AV				
			07	IRKEY_HDMI			07	IRKEY_HDMI				
			06	IRKEY_DVI			06	IRKEY_DVI				
			04	IRKEY_PC			04	IRKEY_PC				

Packet	Command	Data Type	Data		Command	Data Type	Data	
			13	IRKEY_SDI			13	IRKEY_SDI
			09	IRKEY_SELECT			09	IRKEY_SELECT
POWER	03	00	00	POWER ON	03	00	00	POWER ON
			0A	POWER OFF			0A	POWER OFF
		FF	FF	QUERY(Get Current Status)	FF	00	POWER ON	
							0A	POWER OFF
PICTURE MODE	10	00	00	DYNAMIC	10	00	00	DYNAMIC
			01	STANDARD			01	STANDARD
			02	MILD			02	MILD
			03	PERSONAL(USER)			03	PERSONAL(USER)
		80	FF			80	FF	
	81	FF		81	FF			
	FF	FF	QUERY(Get Current Status)	FF	00	STANDARD		
							01	DYNAMIC
							02	SOFT
							03	PERSONAL(USER)
CONTRAST	11	00	32	0 ~ 100	11	00	32	0 ~ 100
			80	FF			80	FF
			81	FF			81	FF
		FF	FF	QUERY(Get Current Status)		FF	32	ex) Current value is 50
BRIGHTNESS Use dimming	12	00	32	0 ~ 100	12	00	32	0 ~ 100
			80	FF			80	FF
			81	FF			81	FF
		FF	FF			FF	32	ex) Current value is 50
SHARPNESS	13	00	32	0 ~ 100	13	00	32	0 ~ 100
			80	FF			80	FF
			81	FF			81	FF
		FF	FF	QUERY(Get Current Status)		FF	32	ex) Current value is 50
TINT(HUE)	14	00	32	0 ~ 100	14	00	32	0 ~ 100
			80	FF			80	FF
			81	FF			81	FF
		FF	FF	QUERY(Get Current Status)		FF	32	ex) Current value is 50
COLOR CHROMA, SATURATION	15	00	32	0 ~ 100	15	00	32	0 ~ 100
			80	FF			80	FF
			81	FF			81	FF
		FF	FF	QUERY(Get Current Status)		FF	32	ex) Current value is 50
COLOR MODE (COLOR TEMP)	16	00	00	COOL	16	00	00	COOL
			01	MEDIUM			01	MEDIUM
			02	WARM			02	WARM
			03	USER			03	USER
	80	FF		80	FF			
	81	FF		81	FF			
	FF	FF	QUERY(Get Current Status)	FF	00	NORMAL		
							01	WARM

Packet	Command	Data Type	Data		Command	Data Type	Data		
							02	COOL	
							03	USER	
COLOR RED RED GAIN	17	00	80	0 ~ 255	17	00	80	0 ~ 255	
		80	FF			80	FF		
		81	FF			81	FF		
		FF	FF	FF		80	ex) Current value is 128		
COLOR GREEN GREEN GAIN	18	00	80	0 ~ 255	18	00	80	0 ~ 255	
		80	FF			80	FF		
		81	FF			81	FF		
		FF	FF	FF		80	ex) Current value is 128		
COLOR BLUE BLUE GAIN	19	00	80	0 ~ 255	19	00	80	0 ~ 255	
		80	FF			80	FF		
		81	FF			81	FF		
		FF	FF	FF		80	ex) Current value is 128		
3DNR	1A	00	00	OFF	1A	00	00	OFF	
			01	WEAK			01	WEAK	
			02	STANDARD			02	STANDARD	
			03	STRONG			03	STRONG	
		80	FF			80	FF		
		81	FF			81	FF		
FF	FF	QUERY(Get Current Status)	FF	02	ex) Current is STANDARD				
BACKLIGHT Use dimming	1B	00	32	0 ~ 100	1B	00	32	0 ~ 100	
		80	FF	-		1B	80	FF	-
		81	FF	-			81	FF	-
		FF	FF	QUERY(Get Current Status)			FF	32	ex) Current value is 50
AUTO COLOR	1C	00	00	AUTO COLOR EXECUTE	1C	00	00	AUTO COLOR EXECUTE	
ADV H POSITION	20	00	32	0 ~ 100	20	00	32	0 ~ 100	
		80	FF			80	FF		
		81	FF			81	FF		
		FF	FF	FF		32	ex) Current value is 50		
ADV V POSITION	21	00	32	0 ~ 100	21	00	32	0 ~ 100	
		80	FF			80	FF		
		81	FF			81	FF		
		FF	FF	FF		32	ex) Current value is 50		
ADV V CLOCK	22	00	32	0 ~ 100	22	00	32	0 ~ 100	
		80	FF			80	FF		
		81	FF			81	FF		
		FF	FF	FF		32	ex) Current value is 50		
ADV V PHASE	23	00	32	0 ~ 100	23	00	32	0 ~ 100	
		80	FF			80	FF		
		81	FF			81	FF		
		FF	FF	FF		32	ex) Current value is 50		
ADV AUTO	24	00	00	AUTO ADJUST EXECUTE	24	00	00	AUTO ADJUST EXECUTE	
COLOR CHANNEL	25	00	01	RED	25	00	01	RED	

Packet	Command	Data Type	Data		Command	Data Type	Data	
			02	GREEN			02	GREEN
			03	BLUE			03	BLUE
			04	RGB			04	RGB
		80	FF					
		81	FF					
		FF	FF				<i>QUERY(Get Current Status)</i>	
RED ONLY	26	00	00	OFF	26	00	00	OFF
			01	ON			01	ON
		80	FF					
		81	FF					
		FF	FF				<i>QUERY(Get Current Status)</i>	
GREEN ONLY	27	00	00	OFF	27	00	00	OFF
			01	ON			01	ON
		80	FF					
		81	FF					
		FF	FF				<i>QUERY(Get Current Status)</i>	
BLUE ONLY	28	00	00	OFF	28	00	00	OFF
			01	ON			01	ON
		80	FF					
		81	FF					
		FF	FF				<i>QUERY(Get Current Status)</i>	
OSD MENU STATUS	3F	FF	FF	<i>QUERY(Get Current Status)</i>	3F	FF	00	MENU OFF
				01			MENU ON	
				02			OSD BAR ON	
				03			MENU ON & OSD BAR ON	
MENU LANGUAGE	40	00	00	ENGLISH	40	00	00	ENGLISH
			01	FRENCH			01	FRENCH
			02	SPANISH			02	SPANISH
			03	DEUTSCH			03	DEUTSCH
			04	NERDERLAND			04	NERDERLAND
			05	ITALIANO			05	ITALIANO
			06	RUSSIAN			06	RUSSIAN
		80	FF					
		81	FF					
		FF	FF				<i>QUERY(Get Current Status)</i>	
MENU TRANSPARENCY	41	00	00	100%	41	00	00	100%
			01	75%			01	75%
			02	50%			02	50%
			03	25%			03	25%
			04	0%			04	0%
		80	FF					
		81	FF					
		FF	FF				<i>QUERY(Get Current Status)</i>	
OSD TIMEOUT	42	00	00	OFF	42	00	00	OFF

Packet	Command	Data Type	Data		Command	Data Type	Data		
			01	5 SEC			01	5 SEC	
			02	15 SEC			02	15 SEC	
			03	30 SEC			03	30 SEC	
		80	FF	80			FF		
		81	FF	81			FF		
		FF	FF	QUERY(Get Current Status)			FF	03	ex) Current is 30 SEC
RESTORE DEFAULT	43	00	00	RESTORE DEFAULT EXECUTE	43	00	00	RESTORE DEFAULT EXECUTE	
CVBS SOURCE SETTING	44	00	00	CVBS OFF	44	00	00	CVBS OFF	
			01	CVBS ON			01	CVBS ON	
		80	FF	80			FF		
		81	FF	81			FF		
		FF	FF	FF			FF	QUERY(Get Current Status)	FF
HDMI SOURCE SETTING	45	00	00	HDMI OFF	45	00	00	HDMI OFF	
			01	HDMI ON			01	HDMI ON	
		80	FF	80			FF		
		81	FF	81			FF		
		FF	FF	FF			FF	QUERY(Get Current Status)	FF
DVI SOURCE SETTING	46	00	00	DVI OFF	46	00	00	DVI OFF	
			01	DVI ON			01	DVI ON	
		80	FF	80			FF		
		81	FF	81			FF		
		FF	FF	FF			FF	QUERY(Get Current Status)	FF
RGB SOURCE SETTING	47	00	00	RGB OFF	47	00	00	RGB OFF	
			01	RGB ON			01	RGB ON	
		80	FF	80			FF		
		81	FF	81			FF		
		FF	FF	FF			FF	QUERY(Get Current Status)	FF
SDI SOURCE SETTING	49	00	00	SDI OFF	49	00	00	RGB OFF	
			01	SDION			01	RGB ON	
		80	FF	80			FF		
		81	FF	81			FF		
		FF	FF	FF			FF	QUERY(Get Current Status)	FF
CURRENT INPUT	48	FF	FF	QUERY(Get Current Status)	48	FF	00	Not Active	
							01	CVBS Active	
							02	HDMI Active	
							04	DVI Active	
							08	RGB Active	
							10	SDI Active	
SLEEP TIMER	50	00	00	30 SEC	50	00	00	30 SEC	
			01	1 MIN			01	1 MIN	
			02	2 MIN			02	2 MIN	
			03	5 MIN			03	5 MIN	

Packet	Command	Data Type	Data		Command	Data Type	Data	
			04	10 MIN			04	10 MIN
			05	30 MIN			05	30 MIN
			06	60 MIN			06	60 MIN
			07	120 MIN			07	120 MIN
			08	OFF			08	OFF
		80	FF	80			FF	
		81	FF	81			FF	
FF	FF	FF	00	ex) Current is OFF				
ZOOM MODE	51	00	00	NORMAL	51	00	00	NORMAL
			01	OVER SCAN			01	OVER SCAN
			02	ZOOM			02	ZOOM
		80	FF	80			FF	
		81	FF	81			FF	
		FF	FF	FF			02	ex) Current is ZOOM
AUTO SOURCE	54	00	00	AUTO SOURCE OFF	54	00	00	AUTO SOURCE OFF
			01	AUTO SOURCE ON			01	AUTO SOURCE ON
		80	FF	80			FF	
		81	FF	81			FF	
		FF	FF	FF			01	ex) Current is AUTO SOURCE ON
IMAGE FLIP	56	00	00	FLIP OFF	56	00	00	FLIP OFF
			01	FLIP ON			01	FLIP ON
		80	FF	80			FF	
		81	FF	81			FF	
		FF	FF	FF			01	ex) Current is FLIP ON.
IMAGE MIRROR	57	00	00	MIRROR OFF	57	00	00	MIRROR OFF
			01	MIRROR ON			01	MIRROR ON
		80	FF	80			FF	
		81	FF	81			FF	
		FF	FF	FF			01	ex) Current is MIRROR ON.
LED STATE	59	FF	FF	QUERY(Get Current Status)	59	FF	00	OFF
				01			LED_RED	
				02			LED_GREEN	
				03			LED_AMBER	
				04			LED_RED_Blink	
				05			LED_GREEN_Blink	
				06			LED_AMBER_Blink	
				07			LED_RED_GREEN_TOGGLE	

Packet	Command	Data Type	Data		Command	Data Type	Data				
NIGHT MODE	5A	00	00	NIGHT MODE OFF	5A	00	00	NIGHT MODE OFF			
			01	NIGHT MODE ON (16.33)			01	NIGHT MODE ON (16.33)			
		80	FF	FF		QUERY(Get Current Status)	80	FF	ex) RGB ON		
			81					FF		81	FF
		FF	FF				FF	01			
FLIP-FLOP	FF	00	00		FLIP OFF & FLOP OFF		FF	00		00	FLIP OFF & FLOP OFF
			01		FLIP ON & FLOP OFF					01	FLIP ON & FLOP OFF
			02	FLIP ON & FLOP ON	02	FLIP ON & FLOP ON					
			03	FLIP ONN & FLOP ON	03	FLIP ONN & FLOP ON					
		80	FF	FF	QUERY(Get Current Status)	80		FF	ex) Current is FLIP and FLOP ON.		
			81					FF		81	FF
		FF	FF			FF		02			

### 5.1.3 DataKeys, miscellaneous functions:

Besides image control commands, several other monitor functions (DataKeys) are available. The easiest way to set the parameters is using the N-COM app, but if needed (fi when controlling parameters from a PLC) it is possible to set these using the RS-485 N-COM.

All monitor functions can be set by DataKeys, but just a selection has been described in this manual. Contact us for more information. To avoid unexpected behavior of the monitor, we strongly advise to contact us before using these commands.

The SetKey data package for N-COM DataKey has the following format:

(fixed)

STX	Unit number (address)	Command	Data length	Data [0] Command	Data [1]	Data [2] Value	Data [3]	Checksum	ETX
0x02	0x01	0x94	0x04	0x00	0x00	0x00	0x00	0x64	0x03

- 0x02= 02 start code. Always 0x02
- 0x01 = 01 = unit number of monitor. Always 0x01. The master processes all data from the PC or PLC and takes care the other units also get these data. A reply is always sent to the PC / PLC! Do not send a new message before the reply is received.
- 0x99 = command. Always 0x94 for SetKey (GetKey:0x95, GetKeyReply:0x96)
- 0x04 = number of data bytes
- 0x00 = Command
- 0x00 = Reserved
- 0x00 = Value
- 0x00 = Reserved
- 0xBB = checksum: sum all data (byte 0..8) in hex: 02+01+99+05+14+00+10+80+FF and inverse the byte, take lsb.
- 0x03 = end of frame, always 0x03. No part of checksum.

SetKey Reply:

STX	Address Always 01 (master)	Command	Data length	Checksum	ETX
0x02	0x01	0x9A	0x00	0x62	0x03

Examples:

Touch power module 1 set to enable (on): \$02\$01\$94\$04\$1E\$00\$00\$00\$46\$03

Touch power module 1 set to disable (off): \$02\$01\$94\$04\$1E\$00\$01\$00\$45\$03

Group	Function	Data [0] Command	Data [2] Value	Default value	Data type	Description
Address and control settings	ModuleNumber	0B	0 - 24	0	int	Set module number of display
	ConfigCH1 ConfigCH2 ConfigCH3 ConfigCH4	0D 0E 0F 10	0 - 3	3	Char	configuration input mix: LTP,HTP,MIX,NON (0,1,2,3)
	source1CH1 source2CH2 source3Ch3 source4Ch4	22 23 24 25	0 - 4	0	Char	input source of ch1, 2, 3 and 4
	linMod1Active linMod2Active linMod3Active linMod4Active linMod5Active linMod6Active	28 32 3C 46 50 5A	1 = active 0 = disabled	0	Char	1= Capswitch 2= Encoder/3button 3= Potentiometer 4= Light sensor 5= Fan 6= Analog input
	linMod1Source linMod2Source linMod3Source linMod4Source linMod5Source linMod6Source	(NA) 33 3D 47 (NA) 5B	0 - 4	0	Char	Assign module to dimming source
Button push / push&hold	linMod2EnablePowerOnOff linMod2PushAndHoldFunction linMod3EnablePowerOnOff linMod3PushAndHoldFunction	3A 3B 43 44	0 - 5	0 1 0 1	Char	0= Power ON/OFF 1= Source select 2= Function key up 3= Function key down 4= Power ON 5= Touch power ON/OFF
Backlight settings	DimMinCourse	11	0 - 4095	-	int	Minimum dimming level
	DimMax	13	0 - 4095	-	int	Maximum dimming level
Status LED settings	LedDimLevelFinal					level to LEDs of LIN-BUS
	LedDimMin					scaling of led min value
	LedDimMax					scaling of led max value
Touch power settings	touchConfig	1E	0 - 4	3		0= ON 1= OFF 3= Delayed 4= Delayed inverted
	touchOnDelay	1F		1		if delay selected: value of delay in 100ms for touch
	touchPowerAtInput	26	0 - 30	0	char	Touch only enabled on selected inputs (#1)

## 1) Values within command #26 touchPowerAtInput (V=ENABLED):

value	CVBS	HDMI	DVI	RGB	SDI
0	V	V	V	V	V
1	V				
2		V			
3			V		
4				V	
5					V
6	V	V			
7	V		V		
8	V			V	
9	V				V

value	CVBS	HDMI	DVI	RGB	SDI
16	V	V	V	V	
17	V	V	V		V
18	V	V		V	V
19	V		V	V	V
20		V	V		
21		V		V	
22		V			V
23		V	V	V	
24		V		V	V
25		V	V		V

10	V	V	V		
11	V	V		V	
12	V	V			V
13	V			V	V
14	V		V	V	
15	V		V		V

26		V	V	V	V
27			V	V	
28			V		V
29			V	V	V
30				V	V

## 5.2 S-COM (alternative RS-485) option

We recommend to use N-COM, but for some reasons it might be necessary to use S-com.

Available parameters in S-com mode (RS-485 control):

- BRT - dimming
- PWR - power ON/OFF.
- → IN BROADCAST mode there will be no reply from the monitor. This is to prevent timing issues when replacing monitors.

Protocol parameters:

- RS-485                      - Half duplex
- Frame based               - Baud rate 9600
- Data bits 8                 - 1 stop bit
- no parity

Command strings:

- Address settings: Address based on Unit number. A dimming source input LTP 19-1 must be added to enable S-COM dimming.

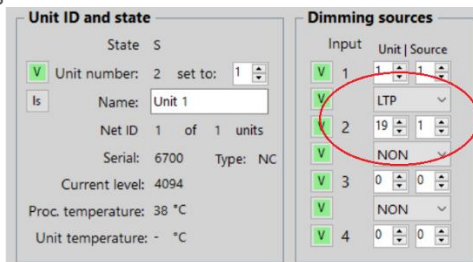

- BRT

- String format:

ATTN	ADDR	CMD	CMD	CMD	LEN	IHCHK	DATA	IDCHK
07	01	42	52	54	01	0E	00	FF

- Enter parameters

- ADDR: Address of unit to control
- IHCHK: Inverse Header Checksum [bytes 0-6]
- DATA: 00=low dimming, FF=full dimming
- IDCHECK: Inverse Data Checksum [DATA +LEN-1]
- Examples
  - BC level A0: \$07\$FF\$42\$52\$54\$01\$10\$A0\$5F
  - BC Level FF: \$07\$FF\$42\$52\$54\$01\$10\$FF\$00

- PWR (MMC)

- String format:

ATTN	ADDR	CMD	CMD	CMD	LEN	IHCHK	DATA-cmd	DATA	IDCHK
07	01	4D	43	43	02	22	9F	30	30

- Enter parameters

- ADDR: Address of unit to control
- IHCHK: Inverse Header Checksum [bytes 0-6]
- DATA
  - DATA-CMD: 9F for PWR
  - DATA: 30 for ON; 2F for OFF
- IDCHECK: Inverse Data Checksum [DATA +LEN-1]
- Examples for Unit 1:
  - ON: \$07\$01\$4D\$43\$43\$02\$22\$9F\$31\$2F
  - OFF: \$07\$01\$4D\$43\$43\$02\$22\$9F\$30\$30
- Examples broadcast:
  - ON: \$07\$FF\$4D\$43\$43\$02\$24\$9F\$31\$2F
  - OFF: \$07\$FF\$4D\$43\$43\$02\$24\$9F\$30\$30

## 5.2.1 Switch from N-COM to S-COM

Connect one single monitor only.

Open the N-COM App V2.0:

- [Open port]
- [Lookup]
- in 'Tools'-tab [Set DC to S-COM]
- [Change com to S-COM]

Test setting: Select message 'TMP', DC address '1 or n', [Send to Address], Wait for the result (noreply might appear shortly)

## 5.2.2 Switch from S-COM to N-COM

Connect one single monitor only.

Open the N-COM App V2.0:

- [Open port]
- [~~Lookup~~] Not in S-COM mode
- in 'Tools'-tab [Set DC to standard]
- [Change com to standard]

re-power the monitor and restart the N-COM App

Switching to N-COM without using the N-COM App use these command strings:

- String format:

ATTN	ADDR	CMD	CMD	CMD	LEN	IHCHK
07	01	6E	6F	74	00	A6

Examples

- Unit 1:           \$07\$01\$6E\$6F\$74\$00\$A6
- Unit 10:         \$07\$0A\$6E\$6F\$74\$00\$9D
- Broadcast:      \$07\$FF\$6E\$6F\$74\$00\$A8

→After setting the unit from S-COM to N-COM, repower the unit to enable correct N-COM functioning.

○

○

## 6 N-COM Application

To be able to make settings in the monitor, the N-COM app needs to be installed on a Windows PC. Depending on the release version the filename is: *Nottrot\_NCOMx\_xx\_Installer.msi* (where *x\_xx* = version)

Double click to install. After installation please start the application from the Windows start-menu: Nottrot - NCOM V2.12 , of course depending on the release version.

After starting the N-COM app the main screen appears.

→ Do not make any changes without sufficient knowledge

The screenshot shows the N-COM application interface with the following sections highlighted by numbered callouts:

- 1**: System network section, including 'Off line' status and 'Open port' button.
- 2**: Net ID list table with columns for Net ID, Unit, Serial, Identify, and State.
- 3**: 'Read, write and store' section with buttons for reading and writing values from DC.
- 4**: Configuration tabs at the top, including 'Configuration', 'OSD configuration', and 'Tools'.
- 5**: 'Unit ID and state' section showing details for 'Unit 1' such as Net ID, Serial, and temperature.
- 6**: 'LinBus module' section with various control options like Encoder, Potentiometer, and Fan control.
- 7**: 'Backlit settings' section for controls, including 'Encoder', 'Potmeter', and 'Cap switch' settings.
- 8**: 'Dimming sources' section showing a list of input sources for dimming.
- 9**: 'Curve' section featuring a graph for selecting and adjusting backlight curves.
- 10**: 'Backlight settings' section for overall backlight parameters like 'Minimum', 'Maximum', and 'Standby level'.
- 11**: 'Miscellaneous functions' section for power control and touch settings.

Group listing. Refer to next sections for detailed description:

- 1- System network : Make connection to the monitors
- 2- ID list : What is connected (in the daisy chain)
- 3- Read, write : Read/write the parameters from the selected (2) monitor
- 4- Tab's : Select configuration for monitor settings
- 5- Unit ID/state : ID and status of selected monitor (double monitor from ID-list (2) click to refresh)
- 6- LinBus module : Select the controls, corresponding ID and assign push functions
- 7- Backlit settings : Backlit behavior for the controls
- 8- Dimming sources: List of dimming sources the selected (2) monitor. Unit refers to Units number (in-external)
- 9- Curves : Select Backlight-TAB to set the curve. Pick the dots and move them.
- 10- Backlight settings: Set backlight limits and control parameters
- 11- Misc. functions : Power control settings for backlight, touch and external control



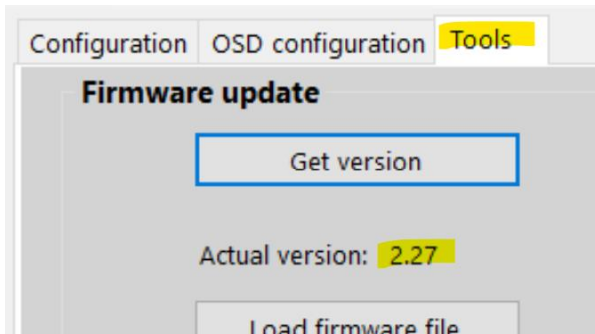

In this example 2.27. You need to use App-version2.xx  
If a version 1.xx is shown, please run App-version 1.xx

## 6.3 Read, write and store

- a) Select the monitor from the ID-list
- b) [Read stored values from DC]
  - All parameters are read from the DC and a 'D' (device) is shown in the status-boxes
  - Changing parameter will directly affect the DC, but changes will be stored in the DC after selecting [Write and store values to DC]. The status-box shows a 'M' (modified)

## 6.4 Configuration-tab

In this section the information of the selected unit (2) is shown.

- a) By double clicking the unit in the table (2) the information is refreshed/updated.

## 6.5 Unit ID and state

- a) Set the Unit number according your dimming configuration. (Refer to 7.1 Configuration plan)

## 6.6 LIN-Bus module

All local LIN-Bus-modules (dimming control devices like potentiometer, encoder, cap-switches, etc.) are configured in this section. Only make changes when adding an external encoder or potentiometer.

→ only one encoder and/or one potentiometer can be used on each monitor. If you need 2 control knobs, use an encoder and potentiometer.

- a) Select the check box to make the module active
- b) Enter the ID for the active modules. This ID is used in Dimming sources.
- c) For the encoder you can enter the steps for dimming 0-100%. Max 255 steps.
- d) Do not change the other parameters.

## 6.7 Control Backlit settings

Control of status LED's, like LED backlight of the dimming devices

- a) Enable/disable the LED
- b) Assign a curve (9)
- c) Set min and max values

## 6.8 Configuration of dimming sources

- a) Set ID (6) and source (5) according configuration plan (Refer to 7.1 Configuration plan)

- b) Action:
- i. LTP = Latest action takes precedence
  - ii. HTP = Highest level takes precedence
  - iii. MIX = average of inputs
  - iv. NON = no action

## 6.9 Setting the dimming curve

→ We do not recommend changing these settings.

## 6.10 Backlight settings

→ We recommend not to change the hardware related settings for PWM, freq and Output.

- a) *Minimum* and *Maximum* settings.
- b) *Standby level* can be set for sleep mode
- c) *Dim to black* will set backlight to zero as a minimum level.

## 6.11 Miscellaneous functions

- a) Backlight control, ON, OFF, delayed, inverted delayed
- b) By enabling Level visible a Backlight level-bar will appear on screen showing the brightness level in %
- c) When using internal power (from monitor) for the touch screen, you can change settings here.

## 7 Installation and parameter settings

Install all units as described in the N-Line user manual. Before connecting the monitors to a power source make sure all connections have been made, but leave the N-COM interconnection cable (RJ45) disconnected. We recommend to connect and set the parameters one by one first. This will avoid double unit numbers being used. This can cause instable control.

Limitations:

- Only one encoder and/or potentiometer can be connected to a monitor. Default the built-in knob is encoder-type, so you can only use a potentiometer as an external dimming knob
- Up to 4 dimming sources can be assigned to a monitor-unit.
- With central dimming configuration only the brightness can be adjusted remotely. There is no central power ON/OFF. The zero configuration also allows remote Power ON/OFF.

To set all user preferences for dimming and OSD control you can use the N-Com application software. Once the configuration is completed you will not need this software. Contact your dealer to get a copy of this software or have the configuration made by your dealer.

### 7.1 Configuration plan

It is essential to prepare a configuration and make a clear plan (on paper) of the configuration you want to create, which knob effects which monitor. For only central dimming it is easy, but when you design a Multi Dimming configuration you might easily get confused. A configuration plan can be given to the dealer to make the configuration for you. You will not need to connect the system to the application software, unless you need to change parameters.

We will use the example given in chapter 2 System overview:

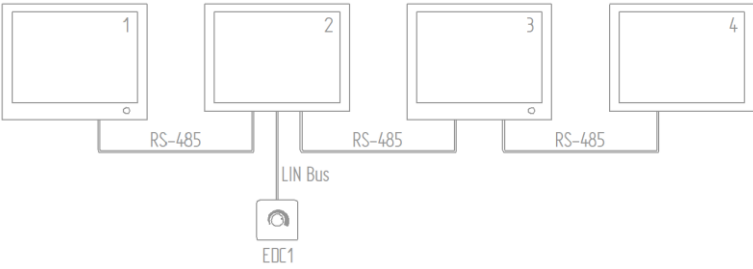
configuration	Description
	<p>(internal and external) dimming knobs on monitor 1, 2 and 3 can control any monitor in the network.</p> <p>Example:</p> <ul style="list-style-type: none"> <li>- Knob 1 controls monitor 1</li> <li>- EDC1 controls all 4 monitors</li> <li>- Knob 3 controls monitors 3 and 4</li> </ul>

In the table below you can see clearly what configuration will be made. This will help make the settings in the application software.

Monitor	LinBUS model ID	Controls monitor	Controlled by monitor
1	1-Encoder	1	1, 2
2	2-EDC1	1, 2, 3 and 4	2
3	3-Encoder	3	2, 3
4	-	-	2

## 8 Example configuration central dimming

In the image below 4 units are shown. From left to right the units will be numbered from 1 to 4. Unit 2 has an external control (potentiometer) that should dim all displays (master). Unit 1 and 3 have a built-in encoder dimming control.

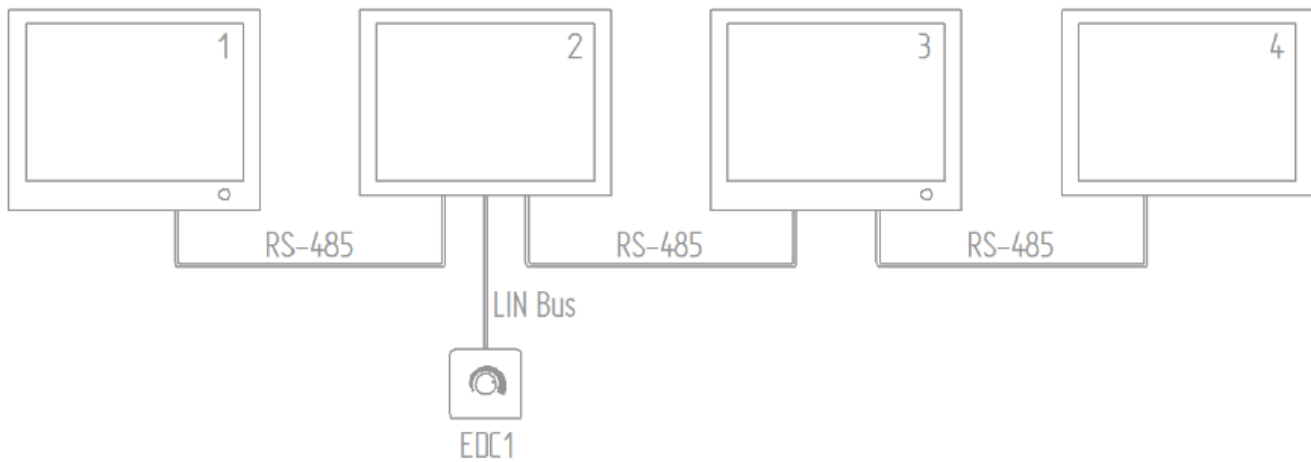

First a configuration plan has to be made. Just make a table as shown below containing and write down all control settings.

Monitor	Control knob/ unit	Controls monitor	Controlled by monitor
1	1	1	1, 2
2	EDC1	1, 2, 3 and 4	2
3	3	3	2, 3
4	-	-	2

Start the application and the following window will appear:

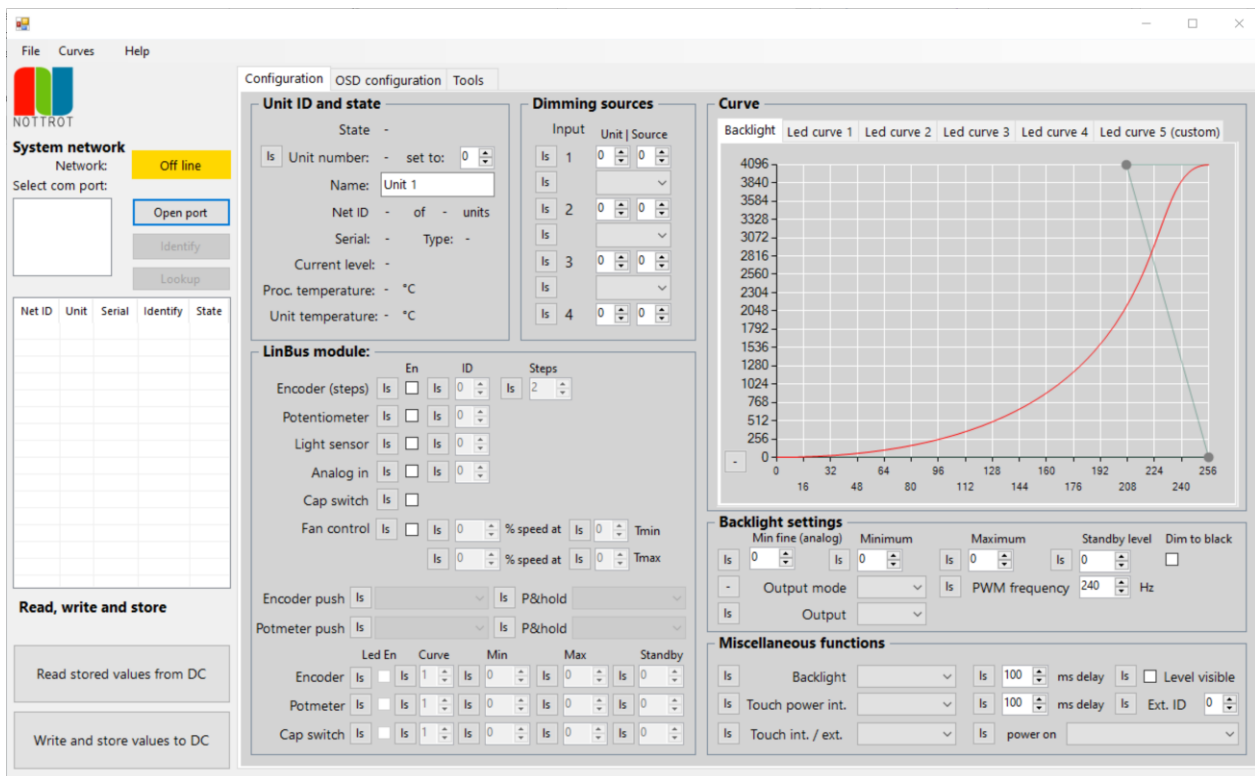

Follow the next steps:

1. Connect unit 1 to the PC using the USB to RS-485 cable. When using this cable for the 1<sup>st</sup> time you need to be connected to the internet to install the drivers. This is done automatically
2. Click [Open port]

Net ID	Unit	Serial	Identifu	State

- a. →If you see more then one COMx port you need to check which COM port is the converter. Disconnect the cable and click [Open port] again. The COM port missing is from the converter.

3. Click [Lookup] and the unit is shown in the list:

Net ID	Unit	Serial	Identify	State
1	0	2329	-	App.

Net ID – Logic address  
 Unit – User defined unit number  
 Serial – Serial number of controller  
 Identify – Blinks when identify function is activated  
 State – App / boot

4. Select the unit to modify in the list and click [Read stored values rom PC]

- a. ..and the configuration window will show all evice values of the selected device:

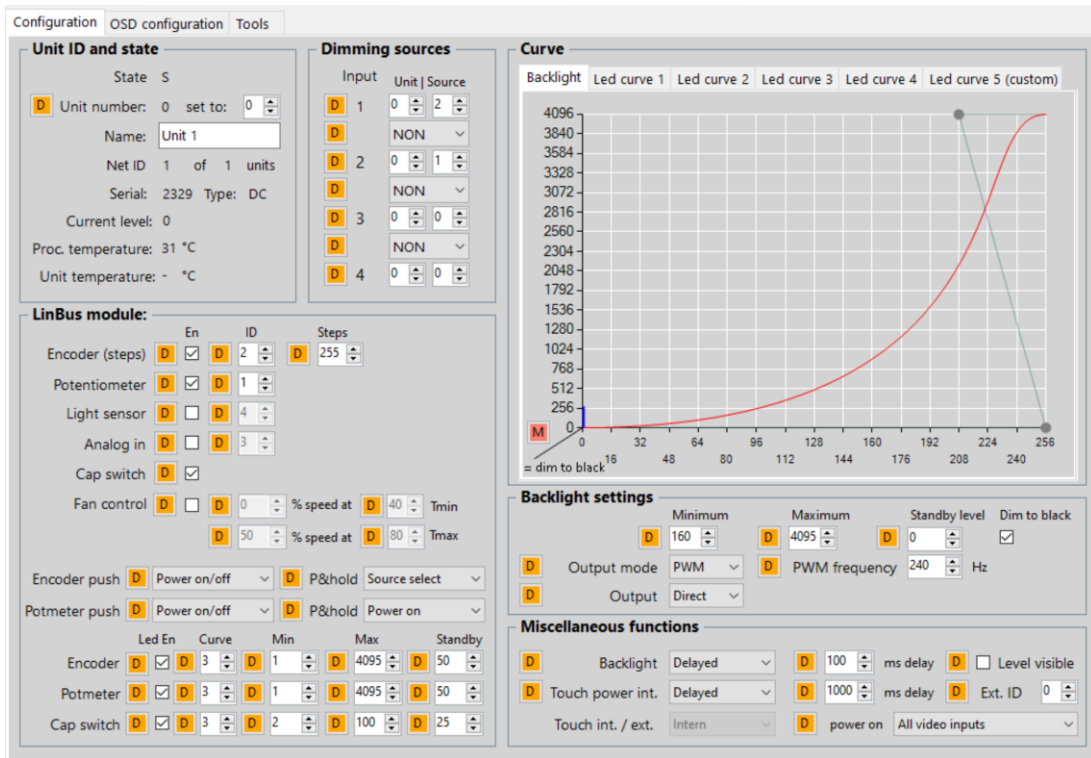

5. Set the Unit number and Dimming sources:

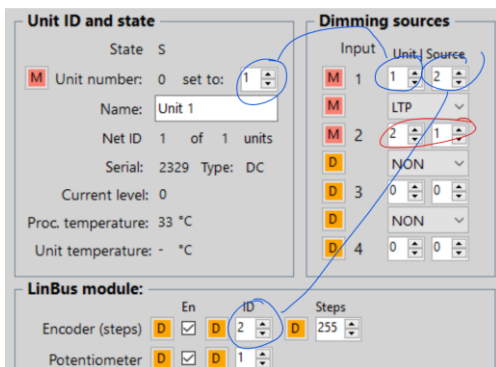

6. Set Unit number to 1. Notice the **D** changing to **M**odified

7. In the Dimming sources section set inputs:
  - a. 1: U1/S2 This is the built in encoder
  - b. 2: U2/S1 This is the external potentiometer hooked up to unit 2, which will be set later.
  - c. LTP-latest takes precedence

8. Click [Write and store values to DC]

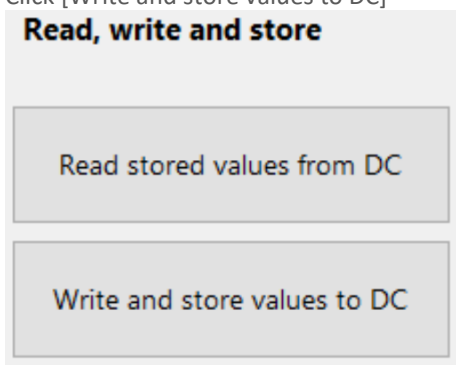

All **D** and **M** to **V**alue

Configuration OSD configuration Tools

### Unit ID and state

State S

Unit number: 0 set to: 1

Name: Unit 1

Net ID 1 of 1 units

Serial: 2329 Type: DC

Current level: 0

Proc. temperature: 33 °C

Unit temperature: - °C

### Dimming sources

Input	Unit	Source
<input checked="" type="checkbox"/> 1	1	LTP
<input checked="" type="checkbox"/> 2	2	NON
<input checked="" type="checkbox"/> 3	0	NON
<input checked="" type="checkbox"/> 4	0	NON

### Curve

Backlight Led curve 1 Led curve 2 Led curve 3 Led curve 4 Led curve 5 (custom)

### LinBus module:

	En	ID	Steps
Encoder (steps)	<input checked="" type="checkbox"/>	2	255
Potentiometer	<input checked="" type="checkbox"/>	1	
Light sensor	<input type="checkbox"/>	4	
Analog in	<input checked="" type="checkbox"/>	3	
Cap switch	<input checked="" type="checkbox"/>		
Fan control	<input type="checkbox"/>	0	% speed at 40 Tmin
		50	% speed at 80 Tmax

Encoder push:  Power on/off  P&hold Source select

Potmeter push:  Power on/off  P&hold Power on

	Led En	Curve	Min	Max	Standby
Encoder	<input checked="" type="checkbox"/>	3	1	4095	50
Potmeter	<input checked="" type="checkbox"/>	3	1	4095	50
Cap switch	<input checked="" type="checkbox"/>	3	2	100	25

### Backlight settings

Minimum:  160 Maximum:  4095 Standby level:  0 Dim to black:

Output mode: PWM PWM frequency: 240 Hz

Output: Direct

### Miscellaneous functions

Backlight: Delayed 100 ms delay  Level visible

Touch power int.: Delayed 1000 ms delay  Ext. ID 0

Touch int. / ext.: Intern power on All video inputs

9. Install a RJ45 (RS-485) cable from Unit 1 to Unit 2 and hookup the external potentiometer (EDC1)

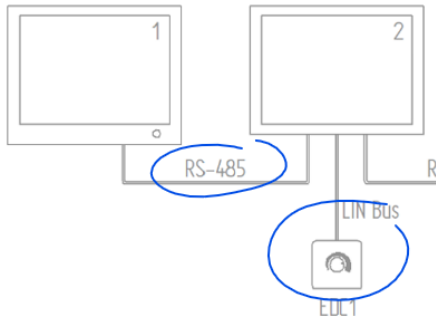

10. Click [Lookup]

Net ID	Unit	Serial	Identify	State
1	1	2329	-	App.
2	0	3328	-	App.

a. A 2<sup>nd</sup> Net ID has been added to the list

11. Select the 2<sup>nd</sup> unit, repeat step 4 – 8 with these parameters:

- a. The only dimming source is Unit 2/Source 2, the external potentiometer.
- b. At this point the dimming of the 2 units can be tested. The external potentiometer controls both screens, the knob on unit 1 controls only unit 1.

12. Install a RJ45 (RS-485) cable between unit 2 and 3

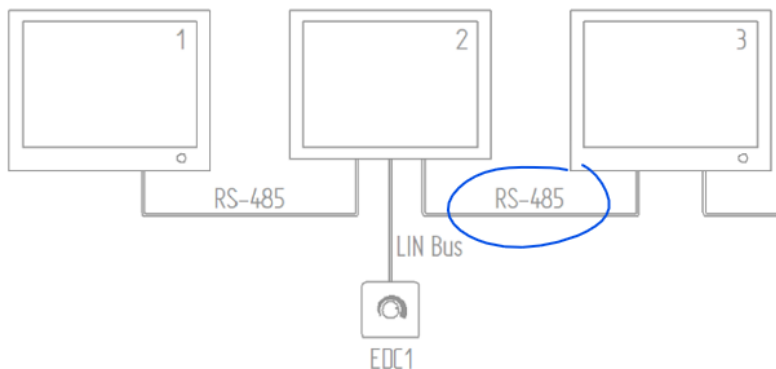

13. Click [Lookup]

Net ID	Unit	Serial	Identify	State
1	1	2329	-	App.
2	2	3328	-	App.
3	0	3328	-	App.

- A 3<sup>rd</sup> Net ID has been added to the list
- Select the 3<sup>rd</sup> unit, repeat step 4 – 8 with these parameters:

The screenshot shows the NOTTROT OSD configuration interface. On the left, the 'System network' section shows 'Network: On line' and 'Select com port: COM4'. Below it is a table with the following data:

Net ID	Unit	Serial	Identify	State
1	1	2329	-	App.
2	2	3328	-	App.
3	0	3328	-	App.

The main configuration area is titled 'Unit ID and state' and shows 'Unit number: 0 set to: 3', 'Name: Unit 1', 'Net ID 3 of 3 units', and 'Serial: 3328 Type: DC'. Below this, 'Current level: 0', 'Proc. temperature: 32 °C', and 'Unit temperature: - °C' are displayed. The 'Dimming sources' section has a table with the following data:

Input	Unit	Source
M 1	3	2
M 2	2	1
D 3	0	0
D 4	0	0

The 'LinBus module' section shows 'Encoder (steps)' with 'En' checked and 'ID' set to 2, and 'Potentiometer' with 'ID' set to 1. Red circles highlight the '3' in the unit number, the '2' in the dimming source unit, and the '1' in the potentiometer ID.

In the red circle you can see that dimming source 1 (=potentiometer) of unit 2 is used.

- Install a RJ45 (RS485) cable between unit 3 and 4

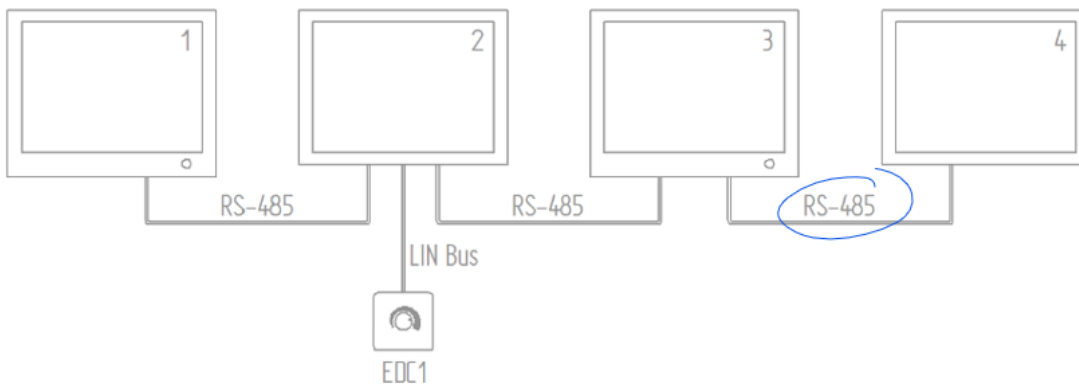

- Click [Lookup]

Net ID	Unit	Serial	Identify	State
1	1	2329	-	App.
2	2	3328	-	App.
3	3	3380	-	App.
4	0	2385	-	App.

- A 4<sup>th</sup> Net ID has been added to the list
- Select the 4<sup>th</sup> unit, repeat step 4 – 8 with these parameters:

Configuration OSD configuration Tools

**Unit ID and state**

State S

Unit number: 0 set to: 4

Name: Unit 1

Net ID 4 of 4 units

Serial: 2385 Type: DC

Current level: 0

Proc. temperature: 24 °C

Unit temperature: - °C

**Dimming sources**

Input	Unit	Source
<input checked="" type="checkbox"/> 1	2	1
<input type="checkbox"/> 2	0	1
<input type="checkbox"/> 3	0	0
<input type="checkbox"/> 4	0	0

**LinBus module:**

	En	ID	Steps
Encoder (steps)	<input checked="" type="checkbox"/>	2	255
Potentiometer	<input checked="" type="checkbox"/>	1	

**System network**

Network: On line

Select com port: COM4

Open port Identify Lookup

Net ID	Unit	Serial	Identify	State
1	1	2329	-	App.
2	2	3328	-	App.
3	3	3380	-	App.
4	0	2385	-	App.

- c. Don't forget to click [Write an store values to DC]. The window should look like this:

Configuration OSD configuration Tools

**Unit ID and state**

State S

Unit number: 4 set to: 4

Name: Unit 1

Net ID 4 of 4 units

Serial: 2385 Type: DC

Current level: 0

Proc. temperature: 26 °C

Unit temperature: - °C

**Dimming sources**

Input	Unit	Source
<input checked="" type="checkbox"/> 1	2	1
<input checked="" type="checkbox"/> 2	0	1
<input checked="" type="checkbox"/> 3	0	0
<input checked="" type="checkbox"/> 4	0	0

**LinBus module:**

	En	ID	Steps
Encoder (steps)	<input checked="" type="checkbox"/>	2	255
Potentiometer	<input checked="" type="checkbox"/>	1	

**System network**

Network: On line

Select com port: COM4

Open port Identify Lookup

Net ID	Unit	Serial	Identify	State
1	1	2329	-	App.
2	2	3328	-	App.
3	3	3380	-	App.
4	4	2385	-	App.

### 8.1.1 Factory default and 0-configuration

The most basic way of central dimming is achieved with the 0-configuration. The monitor will work stand-alone, but you can also control a set of monitors with one master dimming knob without the need of changing parameters.

All units will respond to dimming source ID=1, normally the potentiometer. → **Set Push&hold Action to Power ON.**

The default settings are:

<1 - 0,2>  
LTP  
<2 - 0,1>  
NON  
<3 - 0,0>  
NON  
<4 - 0,0>

You can simply connect the units with a CAT 5 cable. Connect an external potentiometer to the first monitor (master). Reset power and all monitor will dim simultaneously. Dimming of each monitor can still be controlled locally with its own dimming knob. The units will follow the master when operated. Other 0-configuration (master encoder etc) setting are available upon request.

## 9 Firmware update

Them monitor units with N-COM option (=dimming) can be updated using the N-COM-IN connection.

Notes:

- Only use an original USB to RS-485 converter cable: 0901651-x1 N-Com program cable USB/RJ45. This is a tested FTDI based converter.
- Connect only one unit (Monitor or NControl) to the USB to RS-485 converter cable for updating.

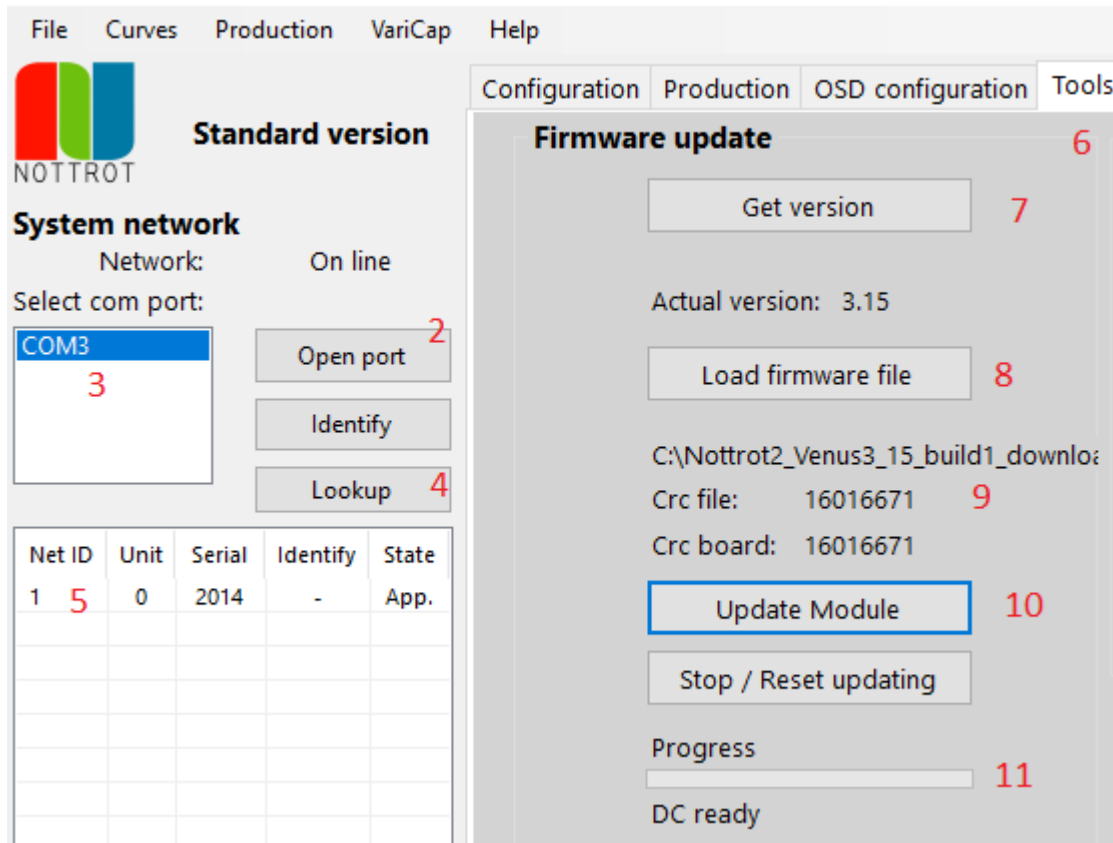

Steps:

1. Start the N-COM app (Use only version 2.4.0.0 or higher)
2. Select [Open port]
3. Select the COM port that your USB to RS-485 converter is plugged in
4. Select [Lookup]
5. Verify that only 1 unit is connected in the Net-ID list
6. Select the Tools-tab
7. Select [Get version] to check the current installed FW
8. Select [Load firmware file]
9. Go to the folder containing the FW-file to be installed. Default location: C:\
10. Select [update module]
11. Now the process (green bar) will start and following messages appear:
  - Set all DC's to boot
  - Reset DC's
  - Download data to unit : 1 (This will take several minutes)
  - Set to App
  - Reset DC
  - DC ready

You can check the FW again by selecting [Get Version].  
If needed connect another unit and repeat steps 3-10

## 10 Trouble shooting

Symptom	Problem	Action
No external control	<ul style="list-style-type: none"> <li>• Wrong baud rate</li> <li>• N-COM App still active</li> </ul>	<ul style="list-style-type: none"> <li>• Check com-port settings</li> <li>• Close N-COM app</li> </ul>
OSD-settings do not function	<ul style="list-style-type: none"> <li>• Commands are not processed in the monitor</li> </ul>	<ul style="list-style-type: none"> <li>• Set right baud rate for RS-232 in the OSD menu. This should be 38400</li> </ul>
Instable control, backlight flicker	<ul style="list-style-type: none"> <li>• Units have the same ID</li> </ul>	<ul style="list-style-type: none"> <li>• Set unique ID's for each monitor.</li> <li>• 0-configuration excepted.</li> </ul>
Monitor backlight is black, even when dimmed to 100%	<ul style="list-style-type: none"> <li>• OSD backlight settings is set to 0</li> </ul>	<ul style="list-style-type: none"> <li>• Re-power to reset backlight settings in OSD</li> </ul>
No reaction on a frame, not even (N)ACK	<ul style="list-style-type: none"> <li>• Last frame is not sent correctly, if wrong checksum</li> </ul>	<ul style="list-style-type: none"> <li>• Send correct frame</li> </ul>